

W Series Heatsinks

For TO-220 and TO-247 devices

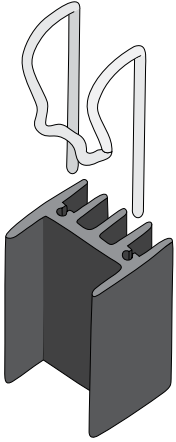

Patent Pending

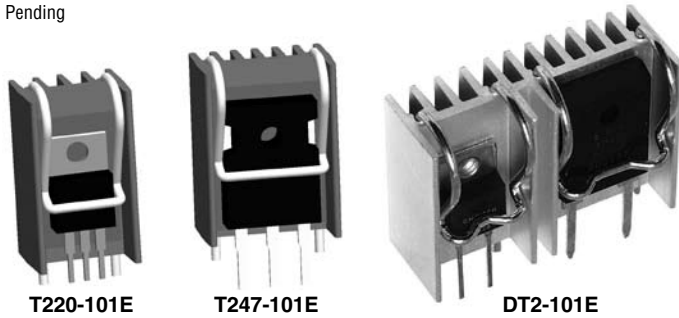
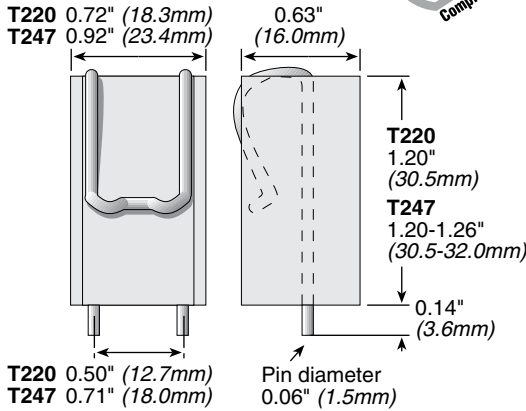

Heatsink Part Number	For Package Type	Ohmite Resistor Series	Surface Area (in ²)	Weight	Thermal Resistance*
WA-T220-101E WV-T220-101E	TO-220	TB25, TCH35	6.5	0.35 oz/10g	R _{s-a} =12°C/W R _{s-a} =13°C/W
WA-T247-101E WV-T247-101E	TO-247	TEH70, TEH100	8.4	0.42 oz/12g	R _{s-a} =11°C/W R _{s-a} =12°C/W
WA-DT2-101E WV-DT2-101E	TO-220 & TO-247	TB25, TCH35, TEH70, TEH100	15.1	0.79 oz/22g	R _{s-a} =7°C/W R _{s-a} =8°C/W

*Natural convection at 10W heat dissipation

LAND PATTERN

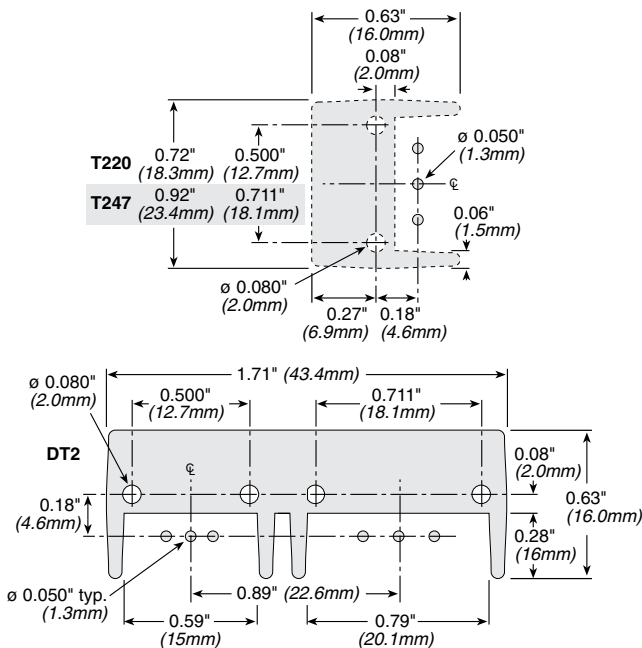

The unique design (patent pending) of the W Series heat sinks combines a tin plated, solderable, integral spring clip with an extruded aluminum heat sink body for an all-in-one solution to through-hole mounting of TO-220 or TO-247 packages. These self-aligning heat sinks feature solderable feet and an integrated clip with 13.2 (lbf) of force on the center of the device to enhance thermal performance.

FEATURES

- **Reduced Assembly Cost:** spring clip and auto-align feature makes fasteners and fixtures obsolete, along with stray metal filings from tapped holes
- **Maximum Repeatability:** clamping force of the spring clip is not degraded by repeated loading and unloading
- **Maximum Heat Transfer per Unit Space:** maximum surface area per unit volume and consistent mounting force reduces thermal resistance
- **Maximum Resistance to Shock and Vibration:** light weight, resilient spring clip locks the component in place and is highly resistant to shock and vibration

- **Maximum Reliability:** helps prevent short circuits by eliminating metal particles from thread tapping
- **RoHS Compliant**

SPECIFICATIONS

- **Heat Sink:** Aluminum alloy 6063-T5 or equivalent.
- **Spring Clip:** Music wire, per ASTM A228
- **Pin:** Solderable 100% tin over copper strike
- **Interface thermal resistance:** for improvement, use thermal joint compound or 0.005 Grafoil (TGon 800 by Laird)
- **Interface electrical isolation:** Sil-Pad 900S by Bergquist or equivalent
- **Mounting:** Vertical thru-hole mount
- **Clip Force:** 13.2 lbf.

HEAT DISSIPATION

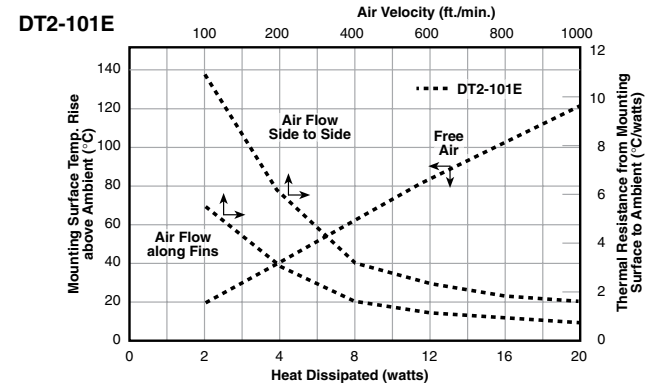
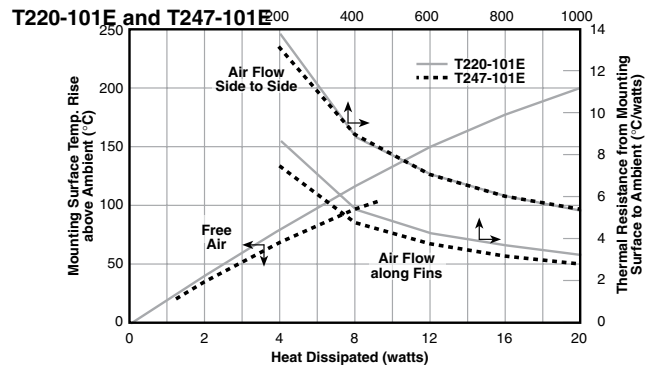

STANDARD PART NUMBERS FOR W SERIES

Part Number	Description	Packaging
WA-T220-101E	Heat sink for TO-220, black anodized	Bulk
WV-T220-101E	Heat sink for TO-220, no finish (degreased)	Bulk
WA-T247-101E	Heat sink for TO-247, black anodized	Bulk
WV-T247-101E	Heat sink for TO-247, no finish (degreased)	Bulk
WA-DT2-101E	Heat sink for TO-247 & TO-220, black anodized	Bulk
WV-DT2-101E	Heat sink for TO-247 & TO-220, no finish (degreased)	Bulk